

DIGITAL MIXER SHOWER



Installation Guide

INSTALLERS PLEASE NOTE THESE INSTRUCTIONS ARE TO BE LEFT WITH THE USER

2181516F - Jan 2019

European Union Registered Design No
004558245-0001/10

TRITON | THE UK'S
SHOWER
COMPANY

See you first thing Britain

Contents

Important Information	3
Standards and approvals	3
Dimensions	7
Digital Controller	7
Digital Mixer Processor Unit	8
Specifications	10
Main Components	11
General Installation Information	12
Typical suitable Installations	13
High Pressure Instantaneous Hot Water Systems	13
High Pressure Unvented Mains Pressure Cylinders	14
High Pressure Thermal Store Systems	15
Low Pressure Gravity Fed Systems	16
Digital Mixer Processor Installation	17
Plumbing Connections	18
Electrical Connections	20
Installation Schematic	21
Digital Controller Installation	22
Data Cable Installation	22
Fixing Bracket Installation	23
Digital Controller Fitting (Wired Connectivity)	24
Digital Controller Fitting (Wireless Connectivity)	26
Commissioning	28
Quick Start	30
General Maintenance	31
Fault Diagnosis	32
Spare Parts	35
Disposal and Recycling	38
Guarantee, Service policy, etc	39

Important information

This book contains all the necessary installation instructions for your Digital Mixer Shower – please read them carefully.

Care taken during the installation will provide a long, trouble-free life from your shower.

The installation must be in accordance with Water Regulations and Bylaws.

BS EN 806 recommends that the temperature of stored water should never exceed 65°C.

A stored water temperature of **60°C** is considered sufficient to meet all normal requirements and will minimise the effects of scale in hard water areas.

Standards and approvals

The processing unit is an independently mounted electronic control. Complies with the requirements of current British and European safety standards for household and similar electrical appliances.

Meets with Compliance with European New Approach Directives (CE).

Declaration of conformity

Triton Showers declares that the HOST/HOME products, in conjunction with controllers, complies with the essential requirements and other relevant provisions of the Low Voltage Directive (2014/35/EU) and the EMC Directive (2014/30/EU) and the RE Directive (2014/53/EU)

Important information

The showerhead and hose supplied with this product are a safety critical part of your shower. Failure to use genuine Triton parts may cause injury and invalidate your guarantee.

Please read this book thoroughly and familiarise yourself with all instructions before commencing installation and keep it for future reference.

The shower installation **MUST** be carried out by a suitably qualified person, following the sequence of this instruction book.

Plumbing

Supply pipes must be flushed to clear debris before connecting the processing unit.

Layout and sizing of pipework **MUST** be such that when other services are used, pressures at the shower control inlets **DO NOT** fall below the recommended minimum.

DO NOT use excessive force when making connections to the Digital Mixer Processor unit.

DO NOT choose a position where the Digital Mixer Processor will become frozen.

DO NOT connect the Digital Mixer Processor unit to any form of tap or fitting not recommended by the manufacturer.

The length of pipework from the Digital Mixer Processor unit to any outlet fitting **MUST NOT** exceed 5m.

Important information

The showerhead or other approved Triton device **MUST** be regularly cleaned to remove scale and debris.

If it is intended to operate the shower in areas of hard water (above 200 ppm temporary hardness), a scale inhibitor may have to be fitted. For advice on the Triton scale inhibitor, please contact Customer Service.

DO NOT operate the Digital Mixer Processor unit outside the guidelines as laid out in 'site requirements' and 'specifications'.

DO NOT connect to a combination cylinder unless the minimum cold storage can be achieved as the shower can deliver up to 16 litres/min.

DO NOT connect the low pressure Digital Mixer Processor unit to the mains water supply as this would damage the unit.

When installed, the top of the low pressure Digital Mixer Processor unit **MUST** be at least 100 mm lower than the base of the cold water cistern to prevent the unit running dry.

A dedicated cold water supply **MUST** be taken directly from the cold water cistern to the low pressure Digital Mixer Processor unit. This draw-off **MUST** be on the opposite side of the cistern to the float operated valve to reduce the risk of air entering the unit.

The inflow to the cistern should be checked to ensure an adequate inflow rate occurs.

Important information

Electrical

The installation must comply with BS 7671 'Requirements for electrical installations' (IEE wiring regulations). Make sure metal incoming hot and cold water supplies to the Digital Mixer Processor unit are adequately earth bonded.

DO NOT turn on the electrical supply until the plumbing connections have been completed. Only then can the electricity be switched on in order to undertake commissioning. The Digital Mixer Processor unit must not be operated dry without water.

The Digital Mixer Processor unit **MUST** be permanently connected to a 3Amp fused connection unit and be provided with means for disconnection incorporated in the fixed electrical wiring in accordance with current wiring regulations.

A 30mA Residual Current Device (RCD) **MUST** be included in the electrical circuit. This may be part of the consumer unit or a separate unit.

If the Digital Mixer Processor unit is to be installed within a bath or shower room the electrical installation **MUST** conform to Part P Building Regulation Requirements for Special Locations.

The Digital Mixer Processor unit **MUST** only be used with the AC power supply cable provided. If this supply cable is damaged, it must be replaced by a Triton engineer or similar qualified persons to avoid a hazard.

Dimensions

Digital Controller (Including Wall Fixing Bracket)

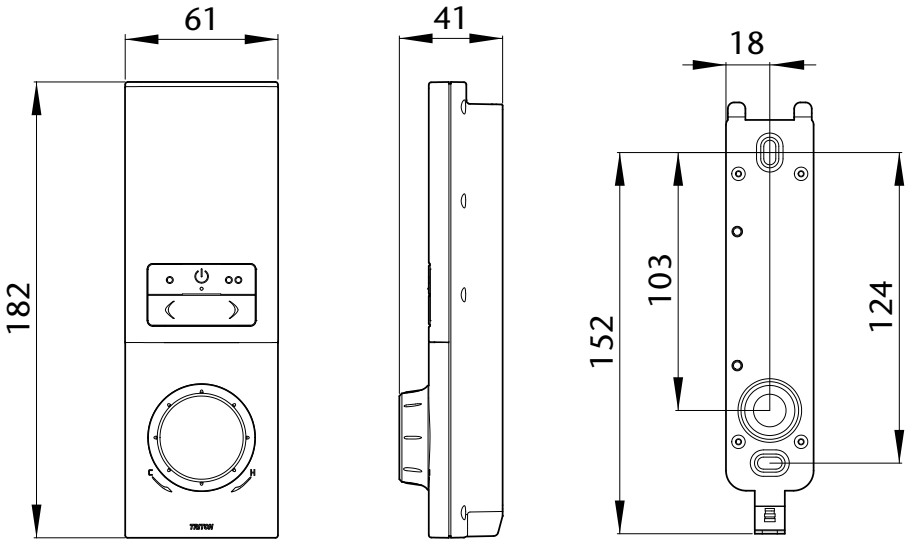

Professional installer Notes

In premises with metallic surfaces e.g. metal ceiling panels, metal ducting and metallic insulating materials, wireless transmissions MAY BE BLOCKED from the control panel and prevent correct operation of the shower.

To check the product suitability for commercial and multiple installations, Please contact Triton's Specification Advisory Service on: 024 7637 2222 for guidance on installations.

Dimensions

Dual Outlet Processor Unit

(High Pressure and Low Pressure)

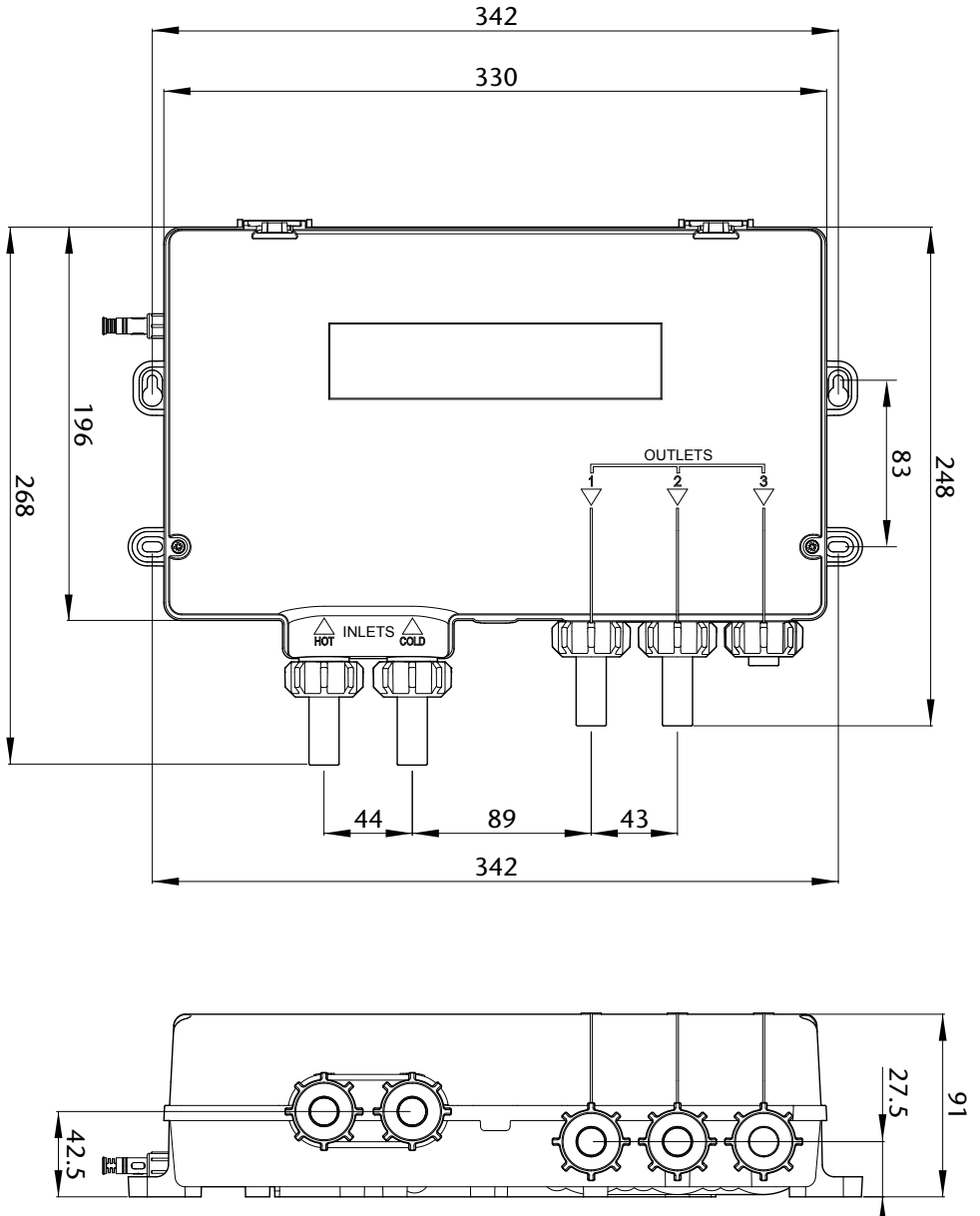

Dimensions

Single Outlet Processor Unit

(High Pressure and Low Pressure)

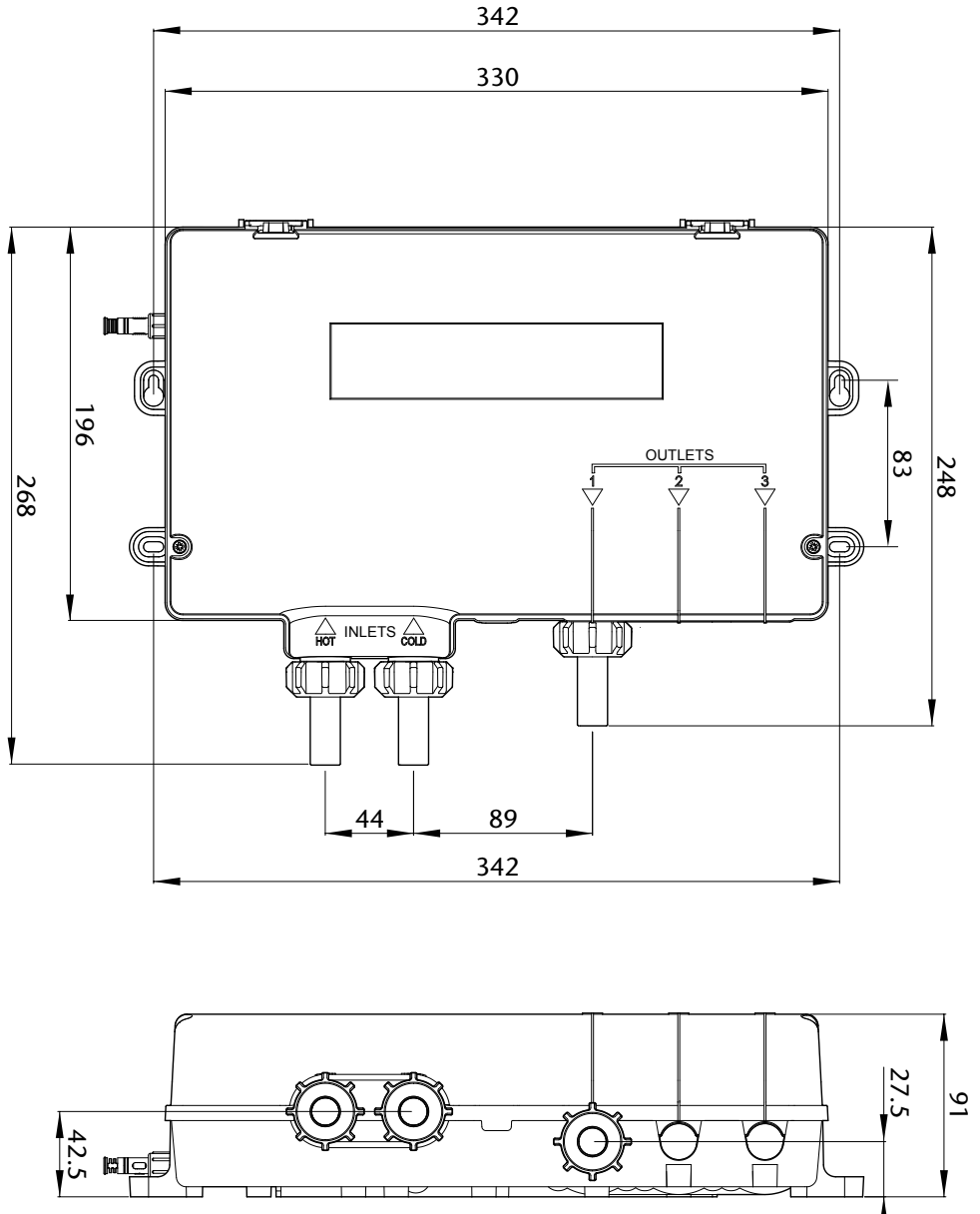

Specification

	Digital processor unit Low pressure/gravity system	Digital processor unit High pressure system
Electrical Mains Supply Maximum Load	230V 50Hz 125 W	230V 50Hz 30 W
Water Inlet Connections Outlet Connections	15 mm push-fit connectors** 15 mm push-fit connectors**	15 mm push-fit connectors** 15 mm push-fit connectors**
Water Pressures Maximum Static Minimum Running Supply Pressure Differential	100 kPa (1bar/10m head) 1 kPa (0.01bar/0.1m head) Nominally Equal	500 kPa (5 bar) 100 kPa (1 bar) Nominally Equal
Temperatures Hot water temperature Cold water temperature Ambient temperature Showering temperature adjustment range	55°C - 65°C 1°C - 20°C 5°C - 40°C 32°C to 47°C*	55°C - 65°C 1°C - 20°C 5°C - 40°C 32°C to 47°C*
Splashproof rating	IP24	IP24

*Max Temperature setting can be adjusted between 41°C and 47°C (factory set at 47°C)

**The Digital Mixer Shower is supplied with 15mm push fit connectors, DO NOT use any other type of fitting

Main components



1. Digital Processor Unit Cover
2. Digital Processor Unit Fixing positions
3. Digital Processor Unit AC Power Lead
4. 15mm push fit connectors with Isolating valves
5. 15mm push fit connectors
6. Digital Processor Unit Inlets (HOT & COLD)
7. Digital Processor Unit Outlets*
8. Digital Processor Unit Data Cable connector

9. Digital Controller
10. Controller Fixing Bracket
11. 10m Data Cable

*(The number of outlets will vary depending on the configuration of the Digital Mixer Shower purchased).

General installation information

The installation MUST BE carried out in accordance with these instructions, and MUST BE undertaken by a qualified competent person.

The Digital Mixer Processor unit may be installed in a loft space, under the bath or in a convenient cupboard space, provided there is enough room for maintenance. Safe and easy access to the Digital Mixer Processor unit should be available at all times.

When planning the installation, if you are using the wired connectivity ensure that the distance between the Digital Mixer Processor unit and Digital Control Panel is within the range of the 10m data cable supplied, ensuring that the data cable routing is taken into consideration.

Ensure that the Digital Mixer Processor unit is installed in a position that will minimise the length of pipe run between the Digital Mixer Processor outlets and the showerhead/ accessory fittings.

The length of pipework running from the Digital Mixer Processor unit to the showerhead/ accessory fittings will have an effect on the showering temperature and the response time when changing the showering temperature on the Digital Control Panel. The shorter the length of pipework the better the Digital Mixer Processor unit will respond.

When installing the Digital Mixer Processor unit in an area not regularly accessed, consideration for potential leaks must be taken into account.

While such events are unlikely, it is advisable to periodically check the installation for traces of water on or around the processor unit. If possible site the Digital Mixer Processor unit in a location where any leak would be contained or routed to avoid areas sensitive to water damage.

Isolation valves are integrated into the push connection fittings supplied for the hot & cold inlets, ensure that after installation these valves are left in the fully open position as failure to do this will result in poor flow performance from the Digital Mixer Shower.

The shower MUST NOT be positioned where it will be subjected to freezing conditions.

All pipe work **MUST** be rigidly supported to avoid any strain on the connections and vibrations during use.

Long inlet pipework (dead-legs) should be kept to a minimum to avoid showering temperature fluctuations

DO NOT connect the Digital Processor unit to a gravity hot supply and a mains cold supply (or vice versa).

The pipework should be installed such that the flow is not significantly affected by other taps and appliances being operated elsewhere on the premises.

There are no user-serviceable components beneath the cover of the Digital Processor unit.

Typical suitable installations

Important if using wireless connected devices

Metal objects such as steel baths, cold water storage tanks, hot water cylinders, radiators, foil lined plaster board and even thick brick walls can all dramatically reduce the wireless operational range.

Interference from other wirelessly controlled devices and radio signals can dramatically reduce the ability of the wireless Digital Mixer Shower to maintain a good, consistent wireless signal. This may include mobile phones, cordless phones, radio controlled toys, wireless doorbells etc.

If you encounter difficulty whilst setting up the wireless connectivity of the Digital Mixer Shower, ensure all other radio interference is temporary switched off.

Failure to follow these wireless connectivity guidelines can result in poor, intermittent or failure of the communication between the Digital Control panel and Digital Mixer Processor unit.

High pressure system – Instantaneous hot water systems, e.g. combination boilers (Fig.1)

The high pressure Digital Mixer Processor unit **MUST** be installed with a multipoint gas water heater or combination boiler of a fully modulating design (i.e. where the water draw-off rate indirectly controls the gas flow rate to the burner).

A drop tight pressure reducing valve **MUST** be fitted if the supply pressures exceed 500kPa (5 bar) running.

An expansion vessel **MUST** be fitted, (and regularly maintained) if any form of backflow prevention device is fitted i.e. PRV. This will ensure that excess expansion or pressure pulses do not damage the product. This may already be installed within the boiler (check with manufacturer) and is in addition to the normally larger central heating expansion vessel.

The layout and sizing of pipework **MUST** be such that nominally equal inlet supply pressures are achieved and the effects of other draw-offs are minimised.

Combination boilers are not always able to supply an adequate flow rate of hot water, particularly in winter, Triton recommends fitting a flow regulator (supplied with the Shower) into the Hot inlet of the High Pressure Digital Processor Unit prior to installation. Refer to the table for details (see Fig.2).

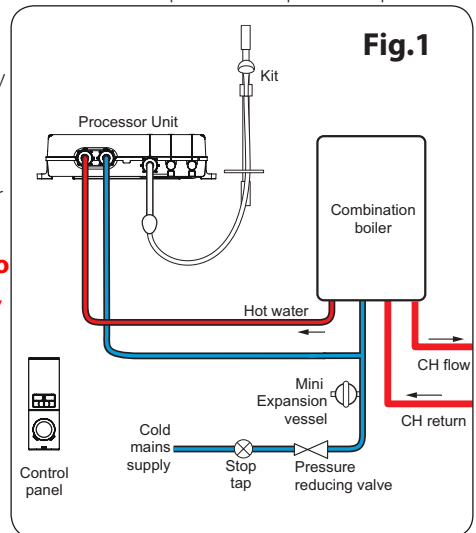

Typical suitable installations

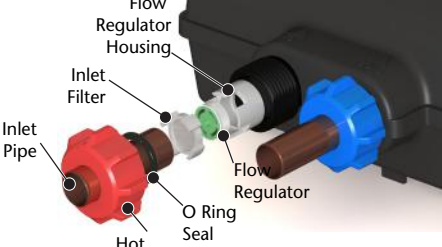

Fig.2

Boiler Rating	Regulator	
24 to 30kW	7 L/min	White/ Green
30 to 36kW	9 L/min	White/ Orange
36kW +	None required	

To fit flow regulator

1. Unscrew the hot inlet nut and remove the inlet pipe, O ring seal, inlet filter and flow regulator housing.
2. Fit the flow regulator into the flow regulator housing.
3. Refit the flow regulator housing, Inlet filter, O ring seal and inlet pipe, secure with the hot inlet nut. Note: the hot inlet nut only requires to be hand tightened.

If using the **Warm Up** feature of the Remote Start/Stop Switch (optional accessory) with a instantaneous water heater appliance the user may experience a brief temperature variation upon restart. This is due to the way in which a combination boiler operates, such that the boiler will turn off after the warm up process has been completed. When restarted, the processing unit will release a cold slug of water followed by a hot slug as the hot water supply stabilises.

High pressure system – Unvented mains pressure cylinders (Fig.3)

The high pressure Digital Mixer Processor unit **MUST** be installed with an unvented, stored hot water cylinder.

For systems with no cold water take off after the appliance reducing valve, it will be necessary to fit an additional drop tight pressure reducing valve when the mains pressure is over 500kPa (5 bar). The drop tight pressure reducing valve **MUST** be set at the same value as the unvented package pressure reducing valve.

Note: An additional expansion vessel (Fig.3) may be required if a second pressure reducing valve is installed. This does not apply to packages with a cold take off after the pressure reducing valve to the cylinder.

The layout and sizing of pipework MUST be such that nominally equal inlet supply pressures are achieved and the effects of other draw-offs are minimised.

Typical suitable installations

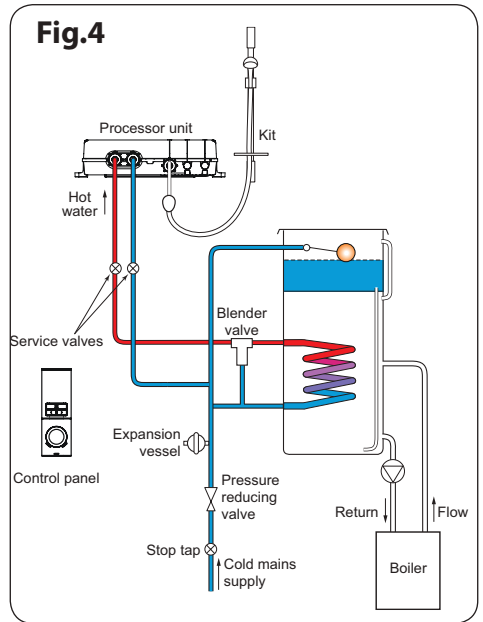
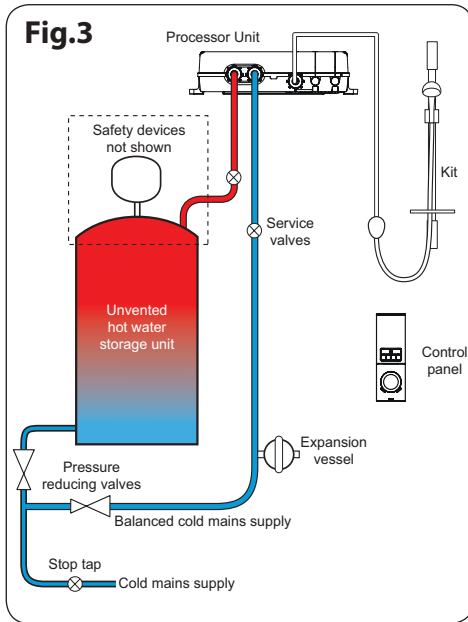

High pressure system – Mains pressurised thermal store systems (Fig.4)

The high pressure system **MUST** be fitted with a tempering valve (blender valve).

The appliance must be capable of raising the temperature of the incoming water to a minimum of 55°C and delivering a flow rate of not less than 8 L/minute

A drop tight pressure reducing valve **MUST** be fitted if the supply pressures exceed 500kPa (5 bar) running.

An expansion vessel (shown in **Fig.4**) **MUST** be fitted, and regularly maintained, to ensure the unit is not damaged by excess pressures. This may already be installed externally or internally within the thermal store (check with thermal store manufacturer).

Typical suitable installations

Only install the low-pressure Digital Mixer Processor with a gravity fed system. Never install a high-pressure digital mixer shower with a gravity fed system

IMPORTANT: The minimum head for operation of the Digital Mixer Processor unit is 100 mm. For correct operation the Digital Mixer Processor unit must not be sited more than 5 metres away from the hot water cylinder.

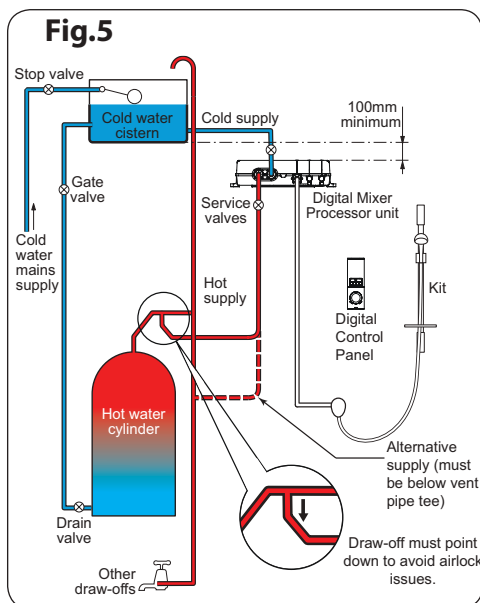

Low pressure system – Gravity fed systems (Fig.5)

The low pressure Digital Mixer Processor unit **MUST** be fed from a cold water cistern and hot water cylinder providing nominally equal pressures.

For the operation of the shower only, it is recommended that the cold water storage cistern is capable of holding at least 114 litres (25 gallons). Where other hot and cold outlets are likely to be in use simultaneously, the storage capacity should be increased to 228 litres (50 gallons) in accordance with BS EN 806.

IMPORTANT: Pipework layouts and connections **MUST** be such that other draw-offs will not effect water supplies to the digital mixer processor unit, shared supplies may lead to air locking or water starvation. It is therefore best practice to have independent hot and cold supplies to the digital mixer processor unit.

If the hot water draw-off is incorrectly positioned, air may be drawn into the hot supply from the vent pipe causing spluttering, temperature fluctuations at the showerhead.

Any draw-off for the processor unit must point DOWN (to avoid air-lock problems) and must be BELOW the vent pipe tee.

Failure to correctly position the draw-off will result in poor performance or other problems with the Digital Mixer Processor unit.

Mixer processor installation

The Digital Mixer Processor unit **MUST** only be positioned as shown.

The Digital Mixer Processor unit can be mounted on a horizontal surface in any orientation **(Fig.6)**.

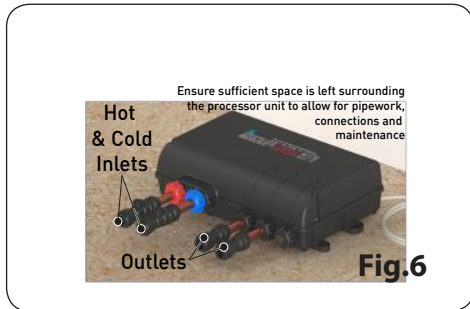

When mounting on a vertical surface the processing unit outlet **MUST** be at the bottom **(Fig.7)**. Failure to position the unit correctly could result in a significant reduction in performance.

Decide on the position for the Digital Mixer Processor unit. Position the Digital Mixer Processor unit in a dry, well ventilated area.

The Digital Mixer Processor unit **MUST** always be positioned either flat on a suitable surface or on a wall so that there is easy access for installation and maintenance.

Mark the four locating screw points for the base. If fixing to brick or a stud partition drill and plug the wall. (The wall plugs provided are suitable for most brick walls — use an appropriate masonry drill, but if the wall is plasterboard or a soft building block, you must use suitable wall plugs and an appropriate drill bit). Secure the Digital Mixer Processor unit in position using the 4 screws supplied **(Fig.8)**

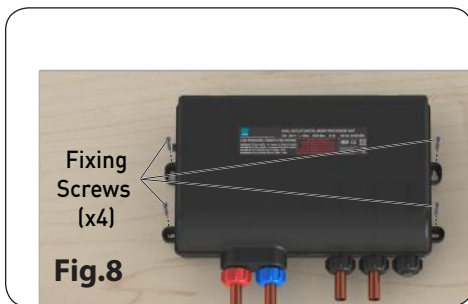

IMPORTANT
If wall mounting the Digital Mixer Processor unit the outlets **MUST** always be at the **BOTTOM (Fig.7)**

Mixer processor installation

If the Digital Mixer Processor unit is installed in a loft area the following requirements must be met for future servicing purposes:

- a. There must be no risk of the Digital Mixer Processor unit or water pipe becoming frozen.
- b. The Digital Mixer Processor unit **MUST NOT** be covered with any form of insulating material that may give rise to electrical circuits overheating during periods of high ambient temperature.
- c. A safe means of access must be provided into the loft, e.g. via a fixed loft ladder.
- d. The Digital Mixer Processor unit **MUST** be installed in an accessible and safe location.
- e. Ceiling joists **MUST** be adequately boarded to provide safe and unobstructed access to, from and around the Digital Mixer Processor unit.
- f. There **MUST** be adequate lighting in the loft for servicing purposes.

Note: If mounting the Digital Mixer Processor unit in a loft it is worth considering building a catchment tank with an overflow pipe directed to an external point. In the unlikely event of a problem occurring with the Digital Mixer Processor unit this will give a visual indication of any failure.

Plumbing connections

Plumbing/Pipe installation to be carried out before electrical wiring installation

DO NOT use jointing compounds on any pipe fitting for the installation.

DO NOT solder fittings near the shower unit as heat can transfer along pipework and damage components.

Fig.9 shows the plumbing connections layout.

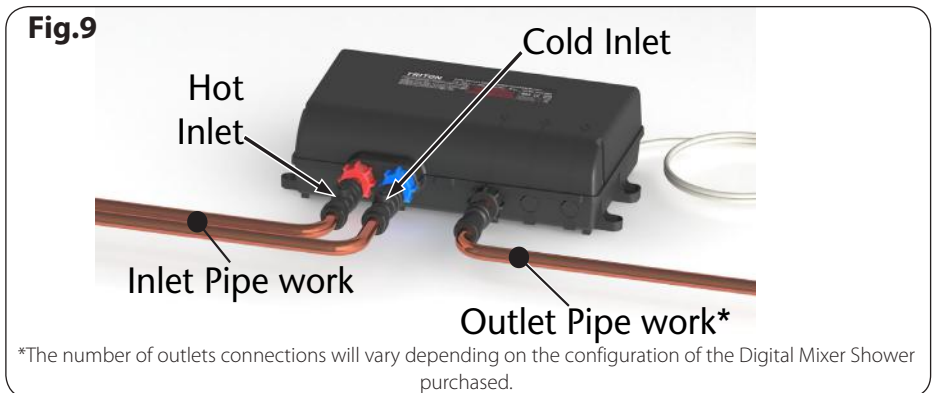

Mixer processor installation

IMPORTANT: The fittings on the inlet and outlets are the push-fit type. The pipework must be cut with a pipe cutter and all burrs and rough edges removed from the end of the tube. The fittings can be used with copper and plastic pipe.

If using chrome plated copper pipe, remove the first 25 mm of plating completely from the connecting surfaces. If not completely removed then the collet will not grip the pipe and under pressure the pipe may be forced out.

Before completing the connection of the water supplies to the inlets of the Digital Mixer Processor unit, flush out the pipework to remove all swarf and system debris.

1. Turn off the water supplies either at the mains stop valve or the isolating stop valve.
2. Having decided on the position of the unit and direction of pipe entry, complete the pipework to the Digital Mixer Processor unit.
3. Check for leaks before connecting the pipework to the Digital Mixer Processor unit.
4. Insert the incoming pipework into the 15 mm push-fit connectors (**Fig.10**).
5. Check that the isolating valves on the inlet connectors are fully open (**Fig.11**).

For products that have more than one outlet then the above procedure of fitting the pipe work will need to be conducted for each outlet.

All pipework should be insulated. DO NOT attempt to insulate or cover the Digital Processor unit

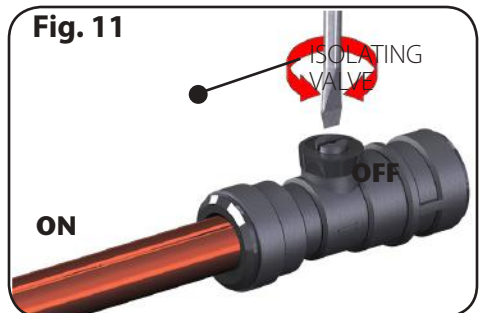
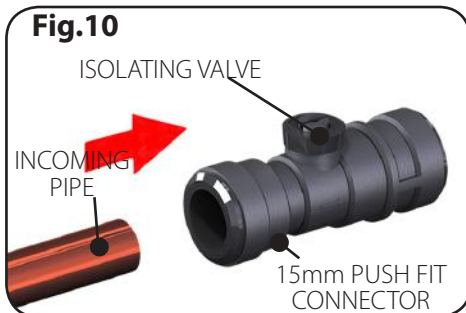

Mixer processor installation

Before any electrical work is attempted, ensure the electricity supply is isolated at the mains switch.

Electrical installation may only be carried out by a qualified person.

Electrical connections

Connect the Digital Processor Unit AC Power Lead to a double pole 3Amp switched fused spur (Fig.12), incorporated in the wiring circuit, in accordance with current wiring regulations.

The 3Amp fused spur MUST be located in a dry, easily accessible position. Access to the fused spur is required for servicing and maintenance

Neutral cable marked **N** Blue

Live cable marked **L** Brown

DO NOT switch on the electricity supply until all the pipe connections have been tested for leaks and the commissioning procedure has been followed.

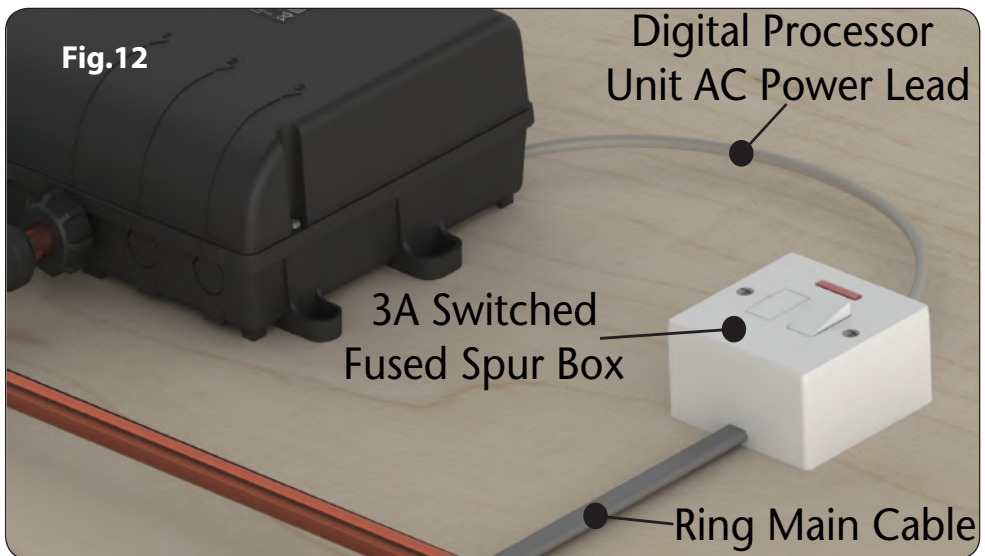

Mixer processor installation

Installation schematic

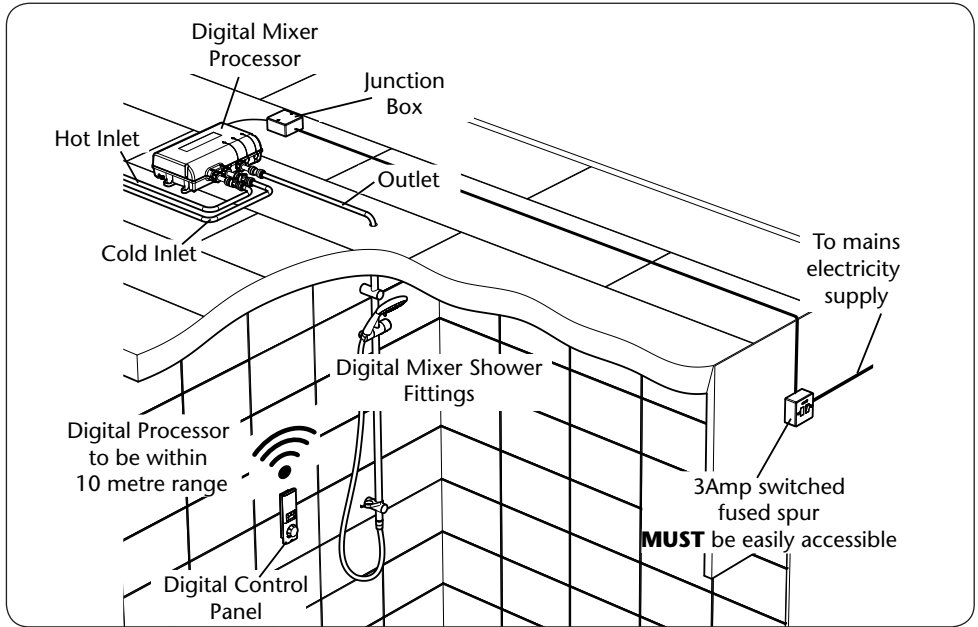

Examples of poor installation practices

- DO NOT** install the Digital Mixer Processor unit where it can become frozen
- DO NOT** install the Digital Mixer Processor unit where it can be subjected to ambient temperatures in excess of 40°C
- DO NOT** position the Digital Mixer Processor unit where maintenance access is poor or unsafe
- DO NOT** install into a system where the cold water cistern holds less than 115 litres (230 litres if other outlets use the same cistern)
- DO NOT** install into a system where air locking could occur
- DO NOT** install the wireless Digital Control Panel in a position where communication with the Digital Mixer Processor unit is poor e.g. installed under a metal bath, in front of a metal cistern, on foil backed plasterboard, outside of the 10 metre range.
- DO NOT** install the Digital Mixer Processor unit onto shared water supplies
- DO NOT** fit plastic pipework unless rigidly supported
- DO NOT** install the low pressure (gravity) Digital Mixer Processor unit less than 100mm from the lowest level of water in the cistern
- DO NOT** install a high pressure/combination boiler Digital Mixer Processor unit to a low pressure pumped gravity system

Digital controller installation

The Digital Controller can be connected to the Digital Mixer Processor unit in two ways, these are: a) 10 metre data cable or b), wirelessly using AA sized batteries.

The Digital Controller has been designed to allow for the installation within a shower cubical or above a bath. The controller must be located whereby the user can start and stop the shower immediately.

Select the desired method of communication and then choose a suitable location for the Digital Controller.

Data cable installation (Wired Connectivity Only)

The data cable is factory fitted to the Digital Mixer Processor unit, ready for a wired installation.

If using wired connectivity, the distance between the Processor unit and Controller MUST BE within the range of the 10m data cable.

Under NO circumstances should the data cable be extended or shortened. The data cable must be connected with the ferrite end attached to the processor unit, as not only will it impair the performance of the shower but it will also invalidate the guarantee.

If the data cable is being routed through wall cavities, chased into solid walls or surface mounted then appropriate trunking/conduit MUST be used. Data cables MUST be fitted in such a way so that they can later be removed for maintenance or servicing

A 15mm diameter hole needs to be made within the showering area to allow for the data cable connection (**Fig.13**).

Make sure there is enough slack cable at the controller end in order for the Digital Controller to be removed should the need arise for future maintenance. Approx 150mm protruding length should be sufficient (**Fig 14**).

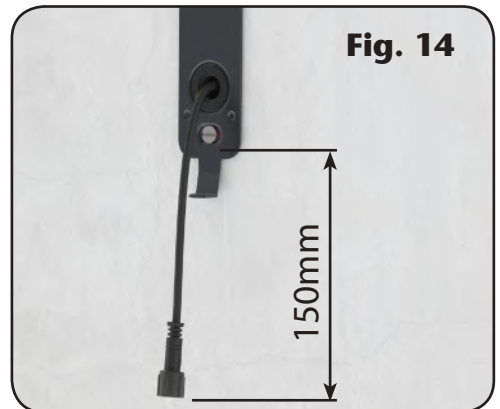
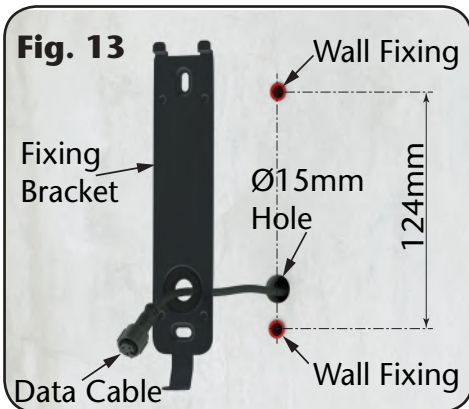

Digital controller installation

Fixing bracket installation

With the Digital Mixer Processor Unit located and the data cable routed it is now time to fit the Digital Controller.

Using the fixing bracket and a spirit level locate the bracket in the desired location, remembering to consider your cable routing position (**Fig. 15**).

Hold the fixing bracket in position and mark the top and bottom screw fixing holes **A** (**Fig 15**). Remove the bracket from the wall then drill and plug the wall for the fixing positions **A**.

(An appropriate drill bit should be used. If the wall is brick, plasterboard or a soft building block, appropriate wall plugs and screws should be fitted).

Secure the mounting bracket to the wall using the appropriate fixings.

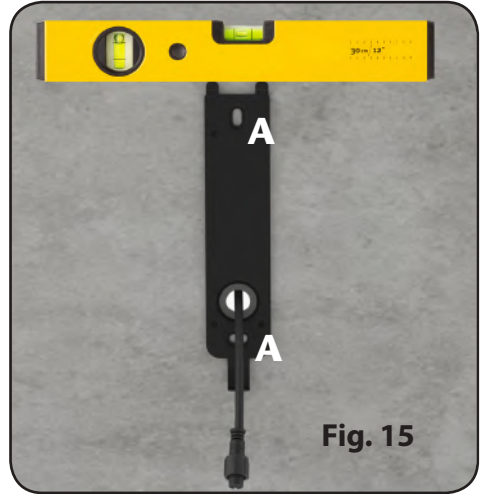

Fig. 15

For Wired Connectivity Only: Whilst securing the mounting bracket to the wall, the data cable must be pulled through so that approx 150mm protrudes from the wall, see (**Fig 14**).

Fitting the data cable

If data cable has been removed and needs to be reconnected to the Digital Mixer Processor Unit at a later date, connect the data cable (**ferrite end, see fig.16**) to the Digital Mixer Processor unit.

On the ends of both the Data Cable and Processor Data Cable Connector are screw connectors, which provide a water tight seal. To ensure that the connectors are correctly assembled and sealed, **ALIGN** the two arrows on both connectors so that they point towards one another, and follow the 3 steps in (Fig 16).

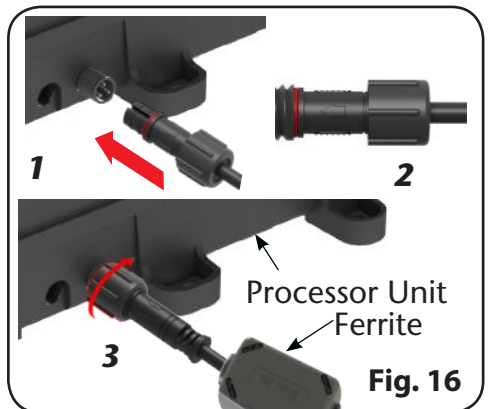

Digital controller installation

If installing the Digital Controller onto a tiled wall, always mount the fixing bracket on the surface of the tiles. NEVER tile up to the Digital Controller.

Digital Controller fitting (Wired connectivity only)

Remove the Battery Compartment Cover on the rear of the Digital Controller by undoing the two fixing screws (Fig 17).

Using a pair of side cutters remove from the Battery Compartment Cover the small plastic tag as shown in (Fig 18).

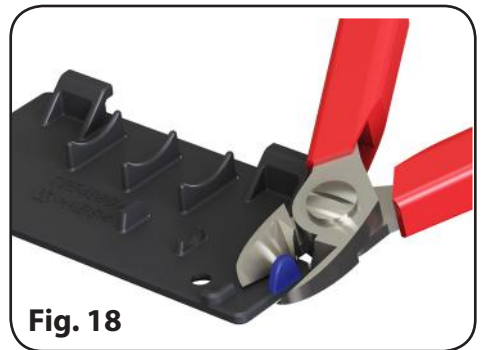

Connect the 3 pin coupler of the Data Cable Connector Lead into the connector located on the PCB within the Digital Controller. Taking care, push the connector lead in to the grooves and slot of the Battery Compartment (Fig 19).

The 3 pin coupler can ONLY be fitted one way into the PCB connector, take care with assembly to avoid damage.



Digital controller installation

Replace the Battery Compartment Cover and secure in place using the two fixing screws previously removed.

Ensure that the Battery Compartment Cover sits flush with the rear housing of the Digital Controller and that both retaining screws are tight (**Fig 20**). **Do not over tighten the screws.**

Connect the Data Cable Connector Lead from the Digital Controller to the Data Cable protruding from the fixing bracket (**Fig 21**).



On the ends of both the Data Cable and Data Cable Connecting Lead are screw connectors, which provide a water tight seal. To ensure that the connectors are correctly assembled and sealed, **ALIGN** the two arrows on both connectors so that they point towards one another, and follow the 3 steps in (**Fig 22**).

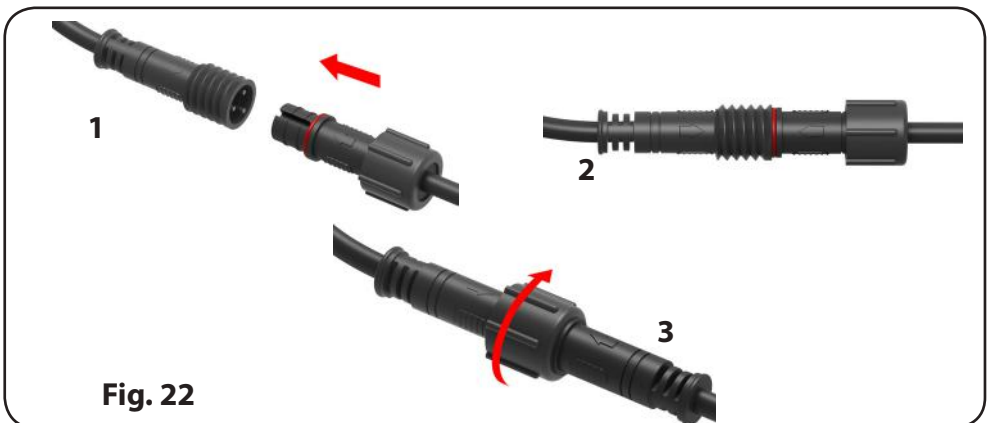

Digital controller installation

Offer the Digital Controller up to the Fixing Bracket. Whilst doing so push the excess Data Cable/Data Cable Connection Lead through the hole within the fixing bracket, and back into the wall cavity.

Fit Digital Controller cut-outs over the Bracket Fixing Lugs (Fig 23) and slide down into place. Secure with the single screw at the bottom of the Digital Controller (**Fig 24**). **Do not over tighten the screw.**

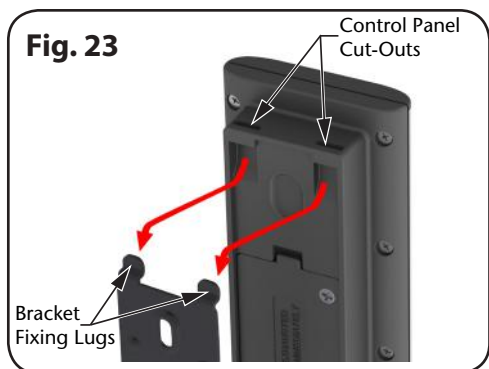

DO NOT turn on the electricity supply to the Digital Mixer Shower until commissioning

Digital Controller fitting (Wireless Connectivity Only)

The factory fitted data cable is not required for wireless installations. It must be disconnected from the Digital Mixer Processor unit before commencing with a wireless installation.

To disconnect the data cable, first unscrew the locking screw collar by turning it anti-clockwise. Reverse the steps shown in **Fig 22**.

Triton recommends that any drilling of holes to secure the wireless Digital Controller is **NOT** undertaken until after commissioning, as the exact final location will need to be tested to ensure that a good, consistent wireless signal is present between the Digital Controller and Digital Mixer Processor unit.

The approximate position of the wireless Digital Control Panel should be no more than 10 metres from the Digital Mixer Processor unit.

Digital controller installation

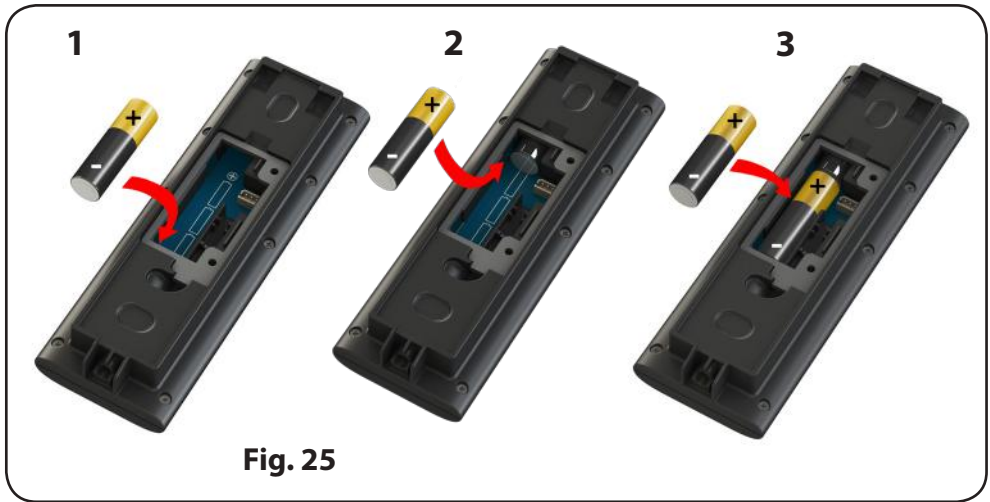

Remove the Battery Compartment Cover on the rear of the Digital Controller by undoing the two fixing screws (**Fig 17**).

Fit 3 x AA sized batteries (not supplied) into the Digital Controller as shown in **Fig 25**.

TRITON recommend the use of Lithium batteries to maximise battery life of the Digital Controller.

Make sure the fitting of the batteries is carried out correctly otherwise the PCB within the Digital Controller could be damaged.

Replace the Battery Compartment Cover and secure in place using the two fixing screws previously removed.

Ensure that the Battery Compartment Cover sits flush with the rear housing of the Digital Controller and that both retaining screws are tight (**Fig 20**). **Do not over tighten the screws.**

Offer the Digital Controller up to the Fixing Bracket.

Fit Digital Controller cut-outs over the Bracket Fixing Lugs (**Fig 23**) and slide down into place. Secure with the single screw at the bottom of the Digital Controller (**Fig 24**). **Do not over tighten the screw.**

Commissioning

While the Digital Mixer Shower is in commissioning mode all other functionality is locked out.

Ensure that the isolating valves on the hot and cold inlets connectors are fully on (**Fig.11**). Turn on the water supplies and check the entire installation for water leaks.

Commissioning **MUST** be carried out with suitable pipework/hose attached to the shower outlet and with the outlet directed to waste.

Commissioning is to ensure water is purged through the unit and any air is dispelled from the system.

DO NOT run the low pressure Digital Mixer Shower (Pumped version) without water.

Failure to commission the Digital Mixer Shower correctly could cause long term damage to the shower.

Turn on the electrical supply to the Digital Mixer Processor unit.

Wireless connectivity only

With batteries fitted into the Digital Controller, electricity supply to the Digital Processor unit turned on, the wireless connectivity between the Digital Controller and Digital Mixer Processor unit will be automatically undertaken.

If however either of the messages in **Fig. 26** are displayed on the Digital Controller permanently then wireless connectivity should be undertaken manually.

To manually connect the Digital Controller with Digital Mixer Processor unit, ensure that fully charged batteries are fitted into the Digital Controller.

- 1 Isolate the electricity supply to the Digital Mixer Processor Unit
- 2 After at least 1 minute restore the electricity to the Digital Mixer Processor Unit
- 3 Within 2 minutes press and hold the flow control buttons together and hold them down for at least 5 seconds.
- 4 Wireless connectivity should now be reset, if this does not resolve the loss of connection, this process can be repeated.

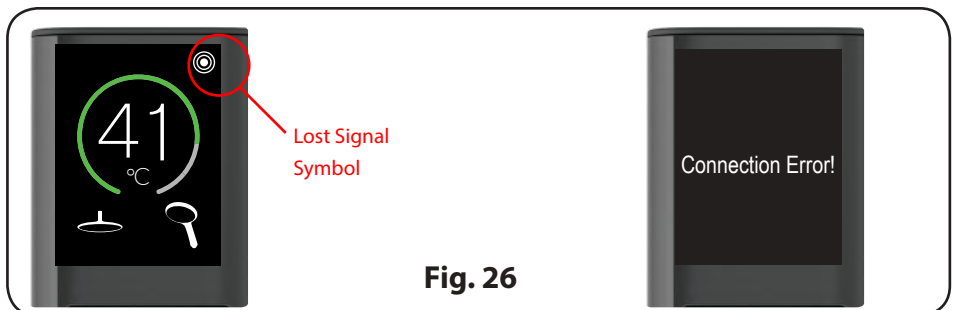

Fig. 26

Commissioning

ENSURE that the position of the wireless Digital Controller is within a 10 metres range of the Digital Mixer Processor unit.

If the symbols in **Fig. 26** are still displayed, then a repositioning of the Digital Controller is required. Ensure that a good, consistent wireless signal is present between the Digital Controller and Digital Mixer Processor unit.

During the commissioning mode, the pump is disabled (LP gravity version only), Outlet 1 is opened, flow control is set to maximum and temperature control is set in mid position.

DO NOT run the low pressure Digital Mixer Shower (Pumped version) without a water supply for longer than 5 minutes.

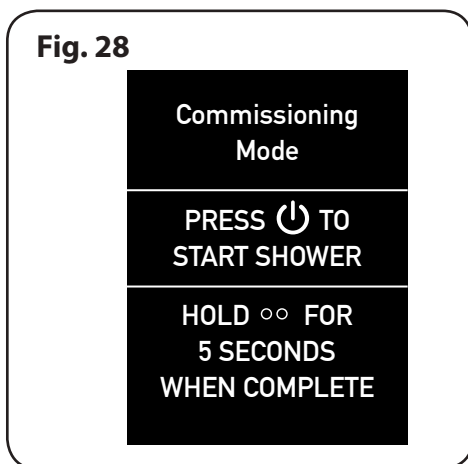
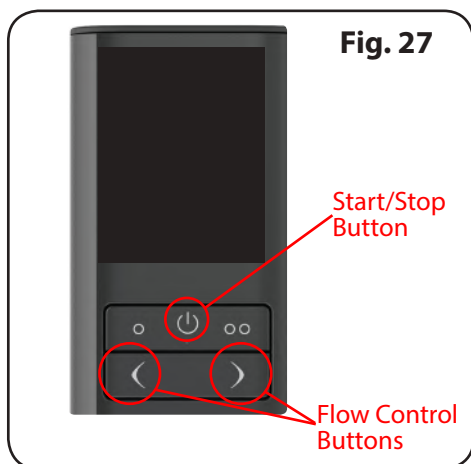

Procedure

The message in **Fig.28** will be displayed on the Digital Controller. To begin the commissioning procedure, press the 'Start/Stop' button (**Fig.27**).

Allow the unit to run for five minutes to dispel any air in the system and to prime both supplies to the unit.



Press and hold outlet 2 (○ ○ symbol) for 5 seconds when the commissioning process is complete, this will set the Digital Mixer Shower into normal operation mode.

It may be necessary to repeat the commissioning procedure , i.e following servicing or maintenance.



This can be reactivated from the configuration menu. Refer to the 'Settings and configuration' section within the user guide.

Quick start



Press the start button  to activate the shower
Alternatively, select your preferred preset, 'Relax / User 1' () or 'Energise / User 2' ()





Adjust the flow rate with the decrease () and increase () buttons.





Adjust the temperature with the temperature dial



Select between your two outlets* using the outlet buttons () / () or press both to run them at the same time



To power down the shower, press the start button , or alternatively deselect the outlets using buttons () / ()

(*outlet selections are only available on multi outlet product versions)

General maintenance

If the Digital Mixer Processor unit is dismantled for any reason during servicing or maintenance, then it **MUST** be inspected to ensure there are no leaks, it is also advised to follow the commissioning procedure to ensure no air has become trapped during the work.

Cleaning

Many household cleaners contain abrasive and chemical substances, and should not be used for cleaning the Digital Controller or any chrome plated fittings. It is recommended that your Digital Mixer Shower system is cleaned regularly with warm, soapy water using a micro fibre cleaning cloth (eg: E-cloth) or sponge **ONLY**.

DO NOT use a general purpose cleaning cloth (eg: J-cloth) dish cloth or scourer.

DO NOT use abrasive or aggressive chemical cleaning products as this may affect the product surface finish and invalidate your guarantee..

It is recommended that the filter is periodically cleaned in order to maintain the performance of the shower. It is essential that this operation is carried out by a competent person.

Cleaning the filters

Using an appropriate flat bladed screwdriver, isolate both the hot and cold inlet valves (**Fig. 11**).

Isolate the electricity supply to the Digital Mixer Processor unit.

Unscrew the inlet nut and remove the inlet pipe, O ring seal, flow regulator housing/Inlet filter.

Remove the inlet filter from the flow regulator housing (**Fig. 28**) and wash thoroughly under running water to remove all debris.

Refit the flow regulator housing/Inlet filter, O ring seal and inlet pipe, secure with the inlet nut. **Note: the inlet nut only requires to be hand tightened.**



Fault diagnosis

If any maintenance is required then it **MUST** be carried out by a competent trade person or a Triton Engineer. **ENSURE** that the underlying cause of malfunction is resolved before replacing any parts

IMPORTANT - Isolate the electricity supply and remove the circuit fuse before attempting any fault diagnosis inside the Digital Mixer processor

Problem/Symptom	Cause	Action/Cure
Digital Mixer Shower will not turn on/no water flow	Interrupted power supply	Blown fuse or circuit breaker. Check supply Renew or reset fuse or circuit breaker. If it fails again, consult a qualified electrician
		Power cut? Check other appliances and if necessary, contact local Electricity Supply Company
	Batteries in Digital Control panel are flat (wireless only)	Fit new batteries, refer to ' Digital Control Panel Installation '
	Digital Control panel is installed out of range (wireless only)	Reposition the Digital Control Panel, refer to ' Digital Control Panel Installation '
	Inlet Isolating valves not fully open	Check if isolating valves are fully open
	Inlet filters or check valves blocked	Check for a blockage, refer to ' Maintenance '
	Air lock in water supplies (LP unit only)	Purge air from hot and cold supplies to the connectors on the mixer unit, see ' Commissioning '
	Failure of either water supply	Check water elsewhere in the house and, if necessary, contact the local water company
	Loss of wireless connection between control Panel and Processor unit (wireless connectivity only)	Repeat wireless connectivity process, see ' Commissioning '
	Unit malfunction	Contact Triton Customer Service

Fault diagnosis

Problem/Symptom	Cause	Action/Cure
Water too cool or cold	Temperature setting too low	Increase temperature via rotary temperature control. See ' Quick Start '
	'Max Shower Temp' setting set to low	Increase Max Shower Temp setting, refer to ' Configure Settings ' in the user manual
	Supply temperature below 50°C	Set system temperature to a minimum of 55°C, see ' Specification
	Water pressure above maximum specified or imbalanced	Check water pressures are normally equal, refer to ' Specification '
	Combination boiler cutting in/out	Check the use of flow regulators, see ' Typical Suitable Installations '
	Insufficient supply of stored hot water	Check storage capacity of hot water, see ' Typical Suitable Installations '
	Air lock in Digital Mixer Processor unit (LP unit only)	Prime to remove air from the mixing unit, see ' Commissioning '
	Inlet supply connection reversed	Check and if necessary correct, see ' Digital Mixer Processor Installation '
Low Flow Rate	Outlet pipe run is too long	Ensure outlet pipe is thermally lagged, see ' Digital Mixer Processor Installation '
	Flow setting too low	Increase flow by pressing the flow increase button, see ' Quick Start
	Inlet Isolating valves not fully open	Check if isolating valves are fully open
	Blockage in inlet filters or check valves	Check for a blockage, refer to ' Maintenance
	Blockage in pipework	Turn off the shower and consult a suitably competent plumber
	Blocked showerhead or hose	Clean sprayplate or replace blocked hose
Inlet water pressure low	Check if sufficient water pressure, see ' Specifications	

Fault diagnosis

Problem/Symptom	Cause	Action/Cure
Low Flow Rate	Air lock in Digital Mixer Processor unit	Prime to remove air from the mixing unit, see ' Commissioning '
	Hot inlet flow regulator not suitable/wrongly fitted	Check and refer to ' Typical Suitable Installation '
Shower stops during showering	Maximum showering time reached	Restart the shower by pressing the ' Start ' button, refer to ' Configure Settings ' in the user manual
	Loss of wireless connection between digital Control Panel and Processor unit (wireless connectivity only)	Repeat wireless connectivity process, see ' Commissioning '
	Loss of either water supply	Check water elsewhere in the house and, if necessary, contact the local water company
		Check that water is available to the shower when other outlets are in use
		Wait for stored water to reach temperature
	Air lock in Digital Mixer Processor unit	Check for correct installation, repeat priming to remove air from the mixing unit, see ' Commissioning '
Combination boiler cutting in/out	Check the use of flow regulators, see ' Typical Suitable Installations '	
Digital Control Panel is not very responsive	Loss or Poor wireless signal between Digital control Panel and Processor unit	Check wireless connectivity, see ' Commissioning '
	Unit malfunction	Contact Triton Customer Service
Shower Pulsing (HP mixer unit on combination boiler)	Water supply temperature too low	Increase domestic hot water temperature
	Unbalanced water pressures	Fit a pressure reducing valve in the cold supply to the mixer and set to the same pressure as the hot supply

Fault diagnosis

Problem/Symptom	Cause	Action/Cure
Noise	Air lock in Digital Mixer Processor unit	Check for correct installation, repeat priming to remove air from the mixing unit, see ' Commissioning '
	Water hammer	Ensure all pipework is securely fixed, see ' General Installation Information '
	Unit malfunction	Contact Triton Customer Service

Spare Parts

Genuine Triton spare parts are available from:

tritonshowers.co.uk/spares

OR

Contact Triton Spares Department on **+44 (0) 2476 372 222**.

OR

Email Triton spares department at **spare_parts@tritonshowers.co.uk**.

If you choose to email, please include a telephone number as it may be necessary for one of our team to speak to you directly.

If you require a replacement shower accessory, please visit:
tritonshowers.co.uk/shower-accessories

Failure to use genuine Triton parts may cause injury and invalidate your guarantee.

Disposal and recycling

Batteries

Spent batteries should **NOT** be disposed of with your normal household waste

NEVER dispose of batteries in fire as this may cause them to explode

ALWAYS dispose of batteries in an environmentally friendly manner and in accordance with local regulations

WEEE Directive – Policy Statement

As a producer and a supplier of electric showers, Triton Showers is committed to the protection of the environment via our own environmental policy and the compliance with the **WEEE directive**.

Triton Showers is fully registered with the Environment Agency under the following schemes:

Repic: Producers take-back scheme (PTS), registration number WEE/EJ3466QV

Valpak: Distributor take-back scheme (DTS), registration number 9659

All our electric products are labelled accordingly with the crossed out wheeled bin symbol. This indicates, for disposal purposes at end of life, that these products must be taken to a recognised collection points, such as local authority sites/local recycling centres; this will be free of any charges. **Do not return to Triton Showers.**



Guarantee and service policy

UK SERVICE POLICY

In the event of a product fault or complaint occurring, the following procedure should be followed:

DO NOT REMOVE THE PRODUCT

1. Telephone Customer Service on **024 7637 2222** having available your details including post code, the model number and power rating of the product, together with the date of purchase and, where applicable, details of the particular fault.
2. If required, the Customer Service Advisor will arrange for a qualified engineer to call.
3. All products attended to by a Triton service engineer must be installed in full accordance with the Triton installation guide applicable to the product. (Every product pack contains an installation guide, however, they can also be downloaded free at www.tritonshowers.co.uk).
4. Our engineer will require local parking and if a permit is required, this must be available to the engineer on arrival at the call.
5. It is essential that you or an appointed representative (who must be over 18 years of age) is present for the duration of the service engineer's visit. If the product is in guarantee you must produce proof of purchase.
6. Where a call under the terms of guarantee has been booked and the failure is not product related (i.e. scaling and furring, incorrect water pressure, pressure relief device operation or electrical/plumbing installation fault) a charge will be made. A charge will also be issued if nobody is at home when the service engineer calls or adequate parking/permit is not available.
7. If the product is no longer covered by the guarantee an up-front fixed fee will be charged before the site visit.
8. Your receipt must be retained as proof of purchase. Should proof of purchase not be available on an 'in-guarantee' call, or should the service engineer find that the product is no longer under guarantee, the engineer will charge the same fixed price and the customer will be expected to pay the engineer before he leaves. If payment is not made on the day an administration charge will be added to the fixed charge.
9. If a debt is outstanding from a previous visit, or from any other Triton purchase, Triton reserves the right to withhold service until the debt has been settled.
10. Triton takes the health, safety and wellbeing of its employees very seriously and expects customers to treat all staff members with respect. Should any employee feel threatened or receive abuse, either verbally or physically, Triton reserves the right to withhold service.

Replacement Parts Policy

In line with AMDEA guidelines, Triton retains functional spares for as long as there is a market for them and in most cases, well beyond. Due to the vast array of product types, the life cycle of products can vary and therefore so can the length of time parts can be supplied. Spare parts can be ordered via our online spare parts store or by telephoning Triton Customer Service Spares Department on **024 7637 2222**. Payment should be made by credit / debit card (excluding American Express or Diners Card). Payment can also be made by pre-payment of a pro-forma invoice, by cheque or postal order.

Telephone orders are based on information given during the call. Before contacting Triton, please verify your requirements using the information contained in the user guide. Triton cannot accept liability for incorrect part identification.

TRITON STANDARD GUARANTEE

With the exception of accessories, Triton guarantee the product against all manufacturing defects for a period of **5 years** (for domestic use only) from the date of purchase, provided that it has been installed by a competent person in full accordance with the fitting instructions.

All accessories such as shower heads, hoses and riser rails carry a **1 year** parts only guarantee against manufacturing defects.

Any part found to be defective during this guarantee period we undertake to repair or replace at our option without charge, so long as it has been properly maintained and operated in accordance with the operating instructions and has not been subject to misuse or damage. This product must not be taken apart, modified or repaired except by a person authorised by Triton. This guarantee applies only to products installed within the United Kingdom and does not apply to products used commercially. This guarantee does not affect your statutory rights.

What is not covered:

1. Breakdown due to:
 - a) use other than domestic use by you or your resident family;
 - b) wilful act or neglect;
 - c) any malfunction resulting from the incorrect use or quality of electricity, gas or water or incorrect setting of controls;
 - d) failure to install in accordance with this installation guide.
2. Claims for missing parts once the product has been installed.
3. Repair costs for damage caused by foreign objects or substances.
4. Total loss of the product due to non-availability of parts.
5. Compensation for loss of use of the product or consequential loss of any kind.
6. Call out charges due to an abortive visit or where no fault has been found with the appliance.
7. The cost of repair or replacement of isolating switches, electrical cable, fuses and/or circuit breakers or any other accessories installed at the same time. Replacement of the Pressure Relief Device that only activates when the shower outlet is blocked is also excluded.
8. The cost of routine maintenance, adjustments, overhaul modifications or loss or damage arising therefrom, including the cost of repairing damage, breakdown, malfunction caused by corrosion, furring, frost or exposure to freezing conditions.
9. Call out charges where the water supply cannot be isolated, this includes consequential losses arising from unserviceable supply valves.

For the latest Terms & Conditions please see:

www.tritonshowers.co.uk/terms

TRITON

See you first thing Britain

Triton Showers

Triton Road
Nuneaton
Warwickshire
CV11 4NR

Installer Hotline:

+44 (0) 2476 378 320

Customer Services:

+44 (0) 2476 372 222

Email:

technical@tritonshowers.co.uk
enquire@tritonshowers.co.uk

Website:

tritonshowers.co.uk

Brochure enquiries:

+44 (0) 24 7632 4460



YouTube



#firstthing

Triton Showers is a division of
Norcross Group (Holdings) Limited.
Triton Showers, Triton Road, Nuneaton,
Warwickshire CV11 4NR

It is our policy to improve the design and specification of our products and we reserve the right to depart from the design given without prior notice.